

TCNB - PLASTIC PLUG WITH INTERNAL HEX HEAD

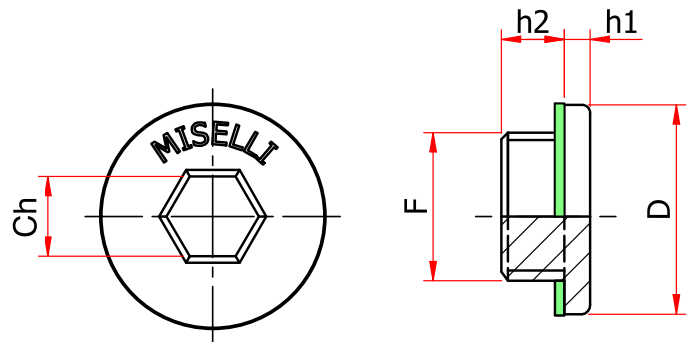

plastic closing plugs

Socket style low profile threaded plug.

- **Material:** reinforced thermoplastic material PA 66 material with 30% fiberglass providing an excellent mechanical resistance at both low and high temperatures.

- **Sealing:** flat fiber gasket.

- **Maximum working temperature:** 100°C/212°F, 120°C/248°F for short periods.

Special versions

- **Sealing:** flat NBR seal or O-Ring 70 Shore.
 - **Material:** Polyamide PA66 reinforced with 50% fiberglass suggested to be used on industrial application where high resistance to deformation and to mechanical shocks are requested. Max operating temperature 120°C/248°F, 150°/302°F for short periods.

Cod.	F	Ch	D	h1	h2	Nm	Nm 50% FV	Pack.
TCNB/14	G 1/4"	6	18	3	8	3÷5	5÷7	100
TCNB/38	G 3/8"	8	22,5	3,5	10,5	6÷8	8÷10	100
TCNB/12	G 1/2"	10	28	4	10	8÷10	10÷12	100
TCNB/34	G 3/4"	12	35	4	10,5	10÷12	18÷20	50
TCNB/14.15	M 14x1,5	6	20	2,5	9	3÷5	5÷7	100
TCNB/16.15	M 16x1,5	8	22,5	3,5	10,5	6÷8	8÷10	100
TCNB/18.15	M 18x1,5	10	26	3	10	7÷9	10÷12	100
TCNB/20.15	M 20x1,5	10	28	3,5	10,5	7÷9	10÷12	100
TCNB/22.15	M 22x1,5	10	28	3,5	10,5	7÷9	10÷12	100
TCNB/26.15	M 26x1,5	12	35	3	11,5	10÷12	18÷20	50